

REC'D 15 APR 2005
WIPO PCT

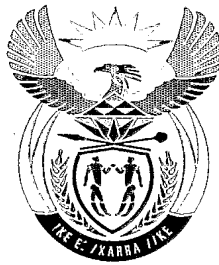

IP/04/04064

Sertifikaat

Certificate

REPUBLIEK VAN SUID AFRIKA

REPUBLIC OF SOUTH AFRICA

PATENT KANTOOR
DEPARTEMENT VAN HANDEL
EN NYWERHEID

PATENT OFFICE
DEPARTMENT OF TRADE AND
INDUSTRY

Hiermee word gesertifiseer dat
This is to certify that

the documents annexed hereto are true copies of:

Application form P.1 and P3, the provisional specification and drawings of South African Patent Application No. 2004/3445 as originally filed in the Republic of South Africa on 6 May 2004 in the name TIEGS, Lonnie Dale for an invention entitled: "SPORTS GEAR".

**PRIORITY
DOCUMENT**
SUBMITTED OR TRANSMITTED IN
COMPLIANCE WITH RULE 17.1(a) OR (b)

Geteken te
Signed at
PRETORIA

in die Republiek van Suid-Afrika, hierdie
in the Republic of South Africa, this

17th dag van
day of February 2005

.....
Registrar of Patents

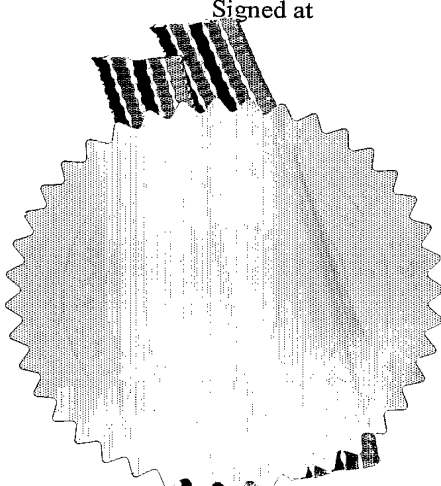

REPUBLIC OF SOUTH AFRICA
 PATENTS ACT, 1978
 APPLICATION FOR A PATENT AND
 ACKNOWLEDGEMENT OF RECEIPT
 (Section 30(1) Regulation 22)

REPUBLIC OF SOUTH AFRICA
 FORM P.1 REVENUE
 (to be lodged in duplicate)
 06.05.04 R 060.00
 HASR 370
 INKOMSTE
 A&A REE...
 A&A REE...
 A&A REE...

THE GRANT OF A PATENT IS HEREBY REQUESTED BY THE UNDERMENTIONED APPLICANT ON THE BASIS OF THE PRESENT APPLICATION FILED IN DUPLICATE

21 01 PATENT APPLICATION NO 2004/3445

71 FULL NAME(S) OF APPLICANT(S)

TIEGS, Lonnie Dale

ADDRESS(ES) OF APPLICANT(S)

5 Cestrum Avenue, Morningside Extension 40, Gauteng Province, Republic of South Africa

54 TITLE OF INVENTION

SPORTS GEAR

Only the items marked with an "X" in the blocks below are applicable.

THE APPLICANT CLAIMS PRIORITY AS SET OUT ON THE ACCOMPANYING FORM P.2. The earliest priority claimed is

Country: No: Date:

THE APPLICATION IS FOR A PATENT OF ADDITION TO PATENT APPLICATION NO 21 01

THIS APPLICATION IS A FRESH APPLICATION IN TERMS OF SECTION 37 AND BASED ON APPLICATION NO 21 01

THIS APPLICATION IS ACCOMPANIED BY:

- A single copy of a provisional specification of 14 pages
- Drawings of 9 sheets
- Publication particulars and abstract (Form P.8 in duplicate) (for complete only)
- A copy of Figure of the drawings (if any) for the abstract (for complete only)
- An assignment of invention
- Certified priority document(s). (State quantity)
- Translation of the priority document(s)
- An assignment of priority rights
- A copy of Form P.2 and the specification of RSA Patent Application No 21 01
- Form P.2 in duplicate
- A declaration and power of attorney on Form P.3
- Request for ante-dating on Form P.4
- Request for classification on Form P.9
- Request for delay of acceptance on Form P.4
- Extra copy of informal drawings (for complete only)

74 ADDRESS FOR SERVICE: Adams & Adams, Pretoria

Dated this 6 day of May 2004

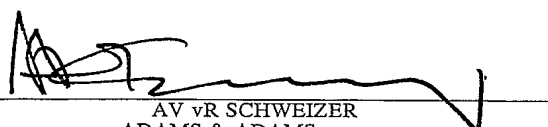
 AV vR SCHWEIZER
 ADAMS & ADAMS
 APPLICANTS PATENT ATTORNEYS

REGISTRAR OF PATENTS DESIGNS,
 TRADE MARKS AND COPYRIGHT
 OFFICIAL DATE STAMP
 2004-05-06
 REGISTRATEUR VAN PATENTE, MODELLE,
 HANDELSMERKE EN OUTEURSREG
 REGISTRAR OF PATENTS

The duplicate will be returned to the applicant's address for service as proof of lodging but is not valid unless endorsed with official stamp

PATENT APPLICATION NO		A&A Ref: V16268 AS/JW/dcd	LODGING DATE	
21	01	• 2004 / 3445	22	6 May 2004

FULL NAME(S) OF APPLICANT(S)	
71	TIEGS, Lonnie Dale

FULL NAME(S) OF INVENTOR(S)	
72	TIEGS, Lonnie Dale

EARLIEST PRIORITY CLAIMED	COUNTRY	NUMBER	DATE
	33	N/A	31
		N/A	32

NOTE: The country must be indicated by its International Abbreviation - see schedule 4 of the Regulations

TITLE OF INVENTION	
54	SPORTS GEAR

- * I/We **Lonnie Dale Tiegs,**
hereby declare that :-
1. I/we am/are the applicant(s) mentioned above;
 - ~~**2. I/we have been authorized by the applicant(s) to make this declaration and have knowledge of the facts herein stated in the capacity of _____ of the applicant(s);~~
 - ~~***3. the inventor(s) of the abovementioned invention is/are the person(s) named above and the applicant(s) has/have acquired the right to apply by virtue of an assignment from the inventor(s);~~
 4. to the best of my/our knowledge and belief, if a patent is granted on the application, there will be no lawful ground for the revocation of the patent;
 - ~~****5. this is a convention application and the earliest application from which priority is claimed as set out above is the first application in a convention country in respect of the invention claimed in any of the claims; and~~
 6. the partners and qualified staff of the firm of **ADAMS & ADAMS**, patent attorneys, are authorised, jointly and severally, with powers of substitution and revocation, to represent the applicant(s) in this application and to be the address for service of the applicant(s) while the application is pending and after a patent has been granted on the application.

SIGNED THIS 22 DAY OF APRIL 2004

Full Names: Lonnie Dale TIEGS

(no legalization necessary)

* In the case of application in the name of a company, partnership or firm, give full names of signatory/signatories, delete paragraph 1, and enter capacity of each signatory in paragraph 2.
 **If the applicant is a natural person, delete paragraph 2.
 ***If the right to apply is not by virtue of an assignment from the inventor(s), delete "an assignment from the inventor(s)" and give details of acquisition of right.
 ****For non-convention applications, delete paragraph 5.

ADAMS & ADAMS
PATENT ATTORNEYS
PRETORIA

REPUBLIC OF SOUTH AFRICA
Patents Act, 1978

PROVISIONAL SPECIFICATION

(Section 30 (1) - Regulation 27)

21	01	OFFICIAL APPLICATION NO
----	----	-------------------------

• 20 04 / 3 4 4 5

22	LODGING DATE
----	--------------

6 May 2004

71	FULL NAME(S) OF APPLICANT(S)
----	------------------------------

TIEGS, Lonnie Dale

72	FULL NAME(S) OF INVENTOR(S)
----	-----------------------------

TIEGS, Lonnie Dale

54	TITLE OF INVENTION
----	--------------------

SPORTS GEAR

This invention relates to sports gear. It more particularly relates to a sports gear assembly, and to an attachment forming part of the sports gear assembly. It relates also to a set of attachments forming part of the sports gear assembly.

It is expected that the invention will particularly advantageously be applicable to outdoor sports such as cycling, in-line skating or rollerblading, snowboarding, skiing, yachting, and the like. Accordingly, such application should particularly be borne in mind when considering this specification.

In accordance with one aspect of the invention there is provided a sports gear assembly which includes securing means for securing the assembly to the head of a sportsperson, and at least one attachment attached to the securing means for location alongside the face and forwardly from an ear of the sportsperson, each attachment being of unitary more or less air-impermeable flexible construction for deflecting flow of air past the head of the sportsperson arising from movement of the sportsperson in a forward direction in which the sportsperson is facing, the deflecting being away from the sportsperson's outer ear canal opening, and acting to reduce wind noise levels experienced by the sportsperson when moving.

It will be appreciated that in sports such as, for example, in-line skating or rollerblading, snowboarding, skiing, and yachting, where a sportsperson's head does not always necessarily face in said forward direction in which the sportsperson moves, each attachment will also act to deflect flow of air past the head of the sportsperson

away from the sportsperson's outer ear canal opening, when the sportsperson's head is, within limits, turned sideways.

Each attachment may be of resiliently flexible plastics foam construction. When of plastics foam construction, each attachment may be in the form of a moulding or casting.

Typically, the assembly will include two attachments attached to opposite sides of the securing means, the attachments respectively being for association with the respective ears of the sportsperson.

The respective attachments may be releasably attached to the securing means. When releasably attached to the securing means, each attachment may include respective releasable attachment formations for effecting said attachment. The attachment formations may be of unitary construction, and may be releasably secured to the associated attachments, so that the attachments and the attachment formations are independently replaceable when worn or damaged.

The attachments may be vertically elongated and may have inner edges for respectively more or less sealingly abutting the respective sides of the face of the sportsperson, the attachments having outer edges which respectively are spaced laterally outwardly from the respective sides of the face of the sportsperson and rearwardly from the inner edges of the attachments, so that the outer edges also define rear edges of the attachments. The resiliently flexible material construction of the attachments facilitates conformation of the inner edges of the attachments with the profiles of the sides of the head of a sportsperson, to effect said sealing abutment.

The attachments may be generally in the form of aerofoils, with front edges thereof defining leading edges and with the outer rear edges thereof defining trailing edges.

The attachments are preferably no shorter than the average adult human pinna or auricle, e.g. about 60 – 70 mm, for deflecting flow of air away from the entire ear of the sportsperson, when the sportsperson moves in a forward direction in which the head of the sportsperson faces. Naturally, the vertical length and the shape of the attachments may be customized by being selected in accordance with the length and shape of a particular sportsperson's ears, and in accordance with an expected or actual angle of attack, which angle of attack varies from sport to sport, which the sportsperson's head is expected to make with air flow past the sportsperson's head.

In one embodiment, the securing means may be in the form of a strap or straps of a helmet, such as a cycling helmet, which strap or straps, in use, extend(s) alongside and under the chin of a sportsperson for securing the helmet to the head of the sportsperson, the attachments being attached to one or more of said straps. In this embodiment, the assembly thus also includes a helmet.

In this embodiment, the attachments may include extensions spaced outwardly from and projecting forwardly from their respective inner edges, to which extensions the attachment formations are secured, the strap(s) of the helmet being for location between operatively inner faces of the extensions and sides of the face of a sportsperson, with the inner edges of the attachments being for location rearwardly from the strap(s). Operatively front edges of the extensions thus define front edges of the respective attachments.

In this embodiment, each attachment formation may include an elongated flexible spine extending at least partially along or adjacent the operatively front edge of its associated extension, and at least two clips fast with and longitudinally spaced along the spine, each clip including a pair of limbs projecting laterally rearwardly from the spine, between which limbs the associated extension is sandwiched, the free ends of each pair of limbs being releasably secured together, and each extension being

provided with an aperture or apertures through which the free end of at least one of the limbs of each pair extends, with the strap(s) of the helmet being held snugly captive between the inner face of each extension and one of the limbs of each clip. It will be appreciated that the attachments are snugly longitudinally slidable along the strap(s), to facilitate adjustment of the vertical positioning of the attachments relative to the ears of the sportsperson.

Each attachment formation will, typically, include three clips longitudinally spaced along the length of the spine and fast with the spine.

In another embodiment, the securing formation may be in the form of a band for receipt around the back of the head and over the ears of a sportsperson. More particularly, the band may be of generally U-shape, when seen in plan view, defining two ear shafts having free ends for respectively resting on the respective ears of the sportsperson, to which free ends the attachments are respectively releasably secured.

The band may be of flexible material construction, to accommodate comfortable receipt thereof by a range of differently shaped heads of sportspeople. Advantageously, the band will be of resiliently flexible material construction. In a particular embodiment, the band will be of resiliently flexible synthetic plastics material. It is also envisaged that, in other embodiments, the band may be constructed of resiliently flexible metal, or constructed of a combination of resiliently flexible synthetic plastics material and resiliently flexible metal.

The band may be constituted by two interconnected parts, each part defining one of the ear shafts, the two parts being slidably interconnected, relative to each other, to provide for adjustment of the length of the band, to accommodate comfortable receipt thereof by a range of differently sized heads of sportspeople, e.g. in the fashion of the adjustable bands at the backs of eye-shades.

In this embodiment, each attachment formation may include a clip secured to its associated attachment and releasably clipped to its associated ear shaft. The clips may be located adjacent upper ends of the attachments, being constructed to provide for pivoting of the attachments relative to the ear shafts, to accommodate for differently shaped heads of sportspeople, and to provide for pivoting of the attachments relative to the ear shafts when the assembly is not secured to the head of a sportsperson. To this end, each attachment formation may also include an elongated flexible stiffening member fast with the clip and releasably secured to the attachment, the stiffening member extending adjacent or along at least part of the length of the front edge of the attachment, with the stiffness of each stiffening member decreasing downwardly along the length thereof, to promote more or less even contact pressure between the inner edges of the attachments and the sides of the face of a sportsperson along the lengths of the inner edges. The assembly, in this embodiment, may also include stops for restricting pivoting of the attachments away from the sides of the head of a sportsperson. Conveniently, said stops will be fast with the respective ear shafts.

The foam-plastics material from which the attachments are constructed may include, or be treated with, an ultra violet protecting agent and an antioxidant for resisting damage to the attachments caused by exposure to sunlight and to damp environments.

In accordance with another aspect of the invention there is provided an attachment, the attachment being as hereinbefore described with reference to the sports gear assembly.

In accordance with a further aspect of the invention there is provided a set of attachments, which set includes two attachments as hereinbefore described, the two attachments respectively being shaped for association with the left ear of a person and for association with the right ear of a sportsperson.

The invention is now described, by way of example, with reference to the accompanying diagrammatic drawings.

In the drawings:

Figure 1 shows a schematic front elevation of a sports gear assembly in accordance with the invention;

Figure 2 shows a schematic side elevation of the sports gear assembly shown in Figure 1;

Figure 3 shows a schematic front elevation of another embodiment of a sports gear assembly in accordance with the invention;

Figure 4 shows a schematic side elevation of the sports gear assembly shown in Figure 3;

Figure 5 shows a schematic side elevation of an attachment forming part of the sports gear assembly shown in Figures 1 and 2;

Figure 6 shows a schematic side elevation of the attachment shown in Figure 5, taken from its other side;

Figure 7 shows a schematic sectional plan view of the assembly shown in Figure 5, the section being taken at VII-VII in Figure 5;

Figure 8 shows a schematic front elevation of the attachment shown in Figure 6;

Figure 9 shows a schematic rear elevation of the attachment shown in Figure 8;

Figure 10 shows, partially, a schematic plan view of the sports gear assembly shown in Figures 3 and 4;

Figure 11 shows a schematic side elevation of an attachment forming part of the assembly shown in Figure 10;

Figure 12 shows a schematic front elevation of the attachment shown in Figure 11.

With reference to Figures 1 and 2 of the drawings, a sports gear assembly in accordance with the invention is generally indicated by reference numeral 10. The assembly 10 includes a cycling helmet 12 received on the head 14 (shown

schematically in broken lines) of a sportsperson, in this case a cyclist, for protecting the head of the cyclist. The cycling helmet 12 is secured to the head 14 of the cyclist by means of securing means in the form of strap assemblies 16, 18, respectively extending alongside the respective sides 42, 44 of the face of the cyclist, the strap assemblies 16, 18 having free ends meeting under the chin of the cyclist and being secured together by means of a clip 20. The securing means, i.e. the strap assemblies 16, 18, form part of the sports gear assembly 10 in accordance with the invention.

The assembly 10 further includes two attachments, both of which, for ease of reference, are indicated by reference numeral 22. The attachments 22 are mirror images of each other in shape and are respectively attached to the strap assemblies 16, 18, such that they are respectively located forwardly of the respective ears 26, 28 (also shown in broken lines) of the cyclist. The strap assemblies 16, 18 each comprise a pair of downwardly converging straps 30, 32 and 34, 36, which are adjustable in length, respectively being spaced in the fore- and aft direction from the ears 26, 28 of the cyclist. Thus, as can be seen in Figure 2, when seen in side view, each pair of straps 30, 32 and 34, 36 forms a downwardly pointing V-shape, with the respective ears 26, 28 of the cyclist being located between the straps 30, 32 and 34, 36 of the respective pairs.

Referring back to the attachments 22, they are shaped and sized such that they deflect flow of air past the head 14 of the cyclist arising from movement of the cyclist in a forward direction, away from the cyclist's ears 26, 28, thereby reducing wind noise levels or volumes experienced by the cyclist while cycling.

The attachments 22 are of unitary more or less air-impermeable flexible plastics foam construction. In this embodiment, the attachments 22 are in the form of mouldings or castings manufactured from viscoelastic plastics foam. The foam plastics from which the attachments are constructed includes an ultra violet protecting agent and an antioxidant for resisting damage to the attachments 22 caused by exposure of the attachments 22 to sunlight and to damp environments.

The attachments 22 are respectively attached to the straps 30, 34, i.e. the straps which are located in the front of the ears 26, 28 of the cyclist.

The attachments 22 are attached to the straps 30, 34 by means of releasable attachment formations 38. For the sake of clarity, the attachment formations 38 are omitted in Figures 1 and 2, as well as in Figures 8 and 9. The attachment formations 22 are, however, shown in detail in Figures 5 – 7.

The attachments 22 are generally in the form of smoothly-contoured aerofoils, having flat inner edges 40 for more or less sealingly abutting the sides 40, 42 of the face of the cyclist, and also having outer edges 46 which are respectively spaced laterally outwardly from the respective sides 42, 44 of the face of the cyclist and spaced rearwardly from the inner edges 40 of the attachments 22. The outer edges 46 of the attachments 22 thus define rear or trailing edges of the attachments 22. Due to the resiliently flexible material construction of the attachments 22, their inner edges 40 conform with the profiles of the sides 42, 44 of the face of the cyclist, to effect said sealing abutment. As can be seen in Figure 2, the width of the attachments 22 is such that, when seen in side elevation, their outer edges 46 are shy of the outer ear canal opening 47 (shown in broken lines) of the cyclist, so that, when seen in side elevation, the outer ear canal opening of the cyclist is exposed. Also, when seen in side elevation, the width of the attachments 22 is such that at a position about one third of their length downward from their upper edges (described hereinafter), the attachments 22 cover about a quarter of the width of the respective ears 26, 28 of the cyclist.

Each attachment 22 is vertically elongated and is slightly longer than its associated ear 26, 28 of the cyclist, thereby to ensure deflection of flow of air past the head 14 of the cyclist, resulting from movement in a forward direction, away from the respective ears 26, 28. Naturally, the vertical length and the shape of the attachments 22 can be customized by being selected in accordance with the length and shape of a

particular cyclist's ears 26, 28, and in accordance with an expected or actual angle of attack which the head 14 of a sportsperson is expected to make with air flow past the sportsperson's head 14. It will be appreciated that said angle of attack varies from sport to sport, so that attachments 22 will be differently shaped and sized for different sports.

Referring now to Figures 5 – 9, the attachments 22 further include extensions 48 spaced laterally outwardly from and projecting forwardly from their respective inner edges 40, to which extensions 48 the attachment formations 38 are releasably secured. Operatively front edges 49 of the extensions 48 thus define front edges of the attachments 22.

Each of the attachment formations 38 includes an elongated flexible synthetic plastics spine 50 which, in this embodiment, extends partially along the front edge 49 of its associated extension 48. Naturally, the spines 50 can, in other embodiments (not shown) extend along the outer faces 61, or if desired along the inner faces 59, of the extensions 48. Furthermore, each attachment formation 38 includes three clips 52 fast with and longitudinally spaced in series from one another along the length of the spine 50. Each clip 52 includes a pair of opposed limbs 54, 56 projecting rearwardly from the spine 50. Free ends the limbs 54, 56 of each pair extend through apertures 58, which apertures 58 extend transversely through the extensions 48. The free ends of the limbs 54, 56 of each pair are releasably secured together by means of clip formations which are not illustrated in the drawings and are not further described. It is, however, to be appreciated that any conventional clip formations can be employed.

The straps 30, 34 (omitted in Figures 5, 7, 8 and 9, with the strap 30 shown in broken lines in Figure 6) are held snugly captive between inner faces 59 of the extensions 48 and the limbs 56 of the clips 52. The attachments 22 are thus snugly longitudinally slidable along their associated straps 30, 34, to facilitate adjustment of the vertical position of the attachments 22 relative to the ears 26, 28 of the cyclist. Further, the limbs 54 of the clips 52 are secured together adjacent their free ends by means of

an elongated resiliently flexible synthetic plastics connector 60. Likewise, the limbs 56 of the clips 52 are secured together adjacent their free ends by means of an elongated resiliently flexible synthetic plastics connector 62. The connectors 60, 62 are more or less parallel to the spine 50 of each attachment formation 38. In other embodiments (not shown), either one of the connectors 60, 62 can be omitted.

The attachment formations 38 are of unitary construction and, due to the fact that they are releasably attached to the attachments 22, the attachments 22 and the attachment formations 38 are independently replaceable when worn or broken.

As can be seen, the inner edges 40 are provided by longitudinally extending rib-like protrusions from the attachments 22, and the upper edges 64 of these protrusions are longitudinally shy of upper edges 66 of the attachments 22, so that, when the attachments 22 are seen in front elevation (Figures 1 and 8), stepped recesses or rebates 68 are defined adjacent their upper edges 66. In use, these recesses provide for receipt of ear shafts of spectacles or sunglasses (not shown).

Referring now to Figures 3 and 4 of the drawings, a further embodiment of a sports gear assembly in accordance with the invention is generally indicated by reference numeral 80. The sports gear assembly 80 in certain respects resembles the sports gear assembly 10 and, accordingly, unless otherwise indicated, parts or features of the assembly 80 similar to or resembling parts or features of the assembly 10, are indicated by the same reference numerals used for the assembly 10.

The securing means for securing the assembly 80 to the head 14 of the sportsperson, is in the form of a band 82 which is of generally U-shape when seen in plan view. In Figure 10 one half of the assembly 80 is omitted. It will, however, be appreciated that the omitted half is an exact mirror image of the half that is shown in Figure 10. The band 80 is thus, as can be seen in Figure 4, received around the back of the head 14 and over the ears 26, 28 of the sportsperson. The assembly 80 is thus

suited for use in sports such as yachting, in-line skating or rollerblading, snowboarding, skiing, and the like where a helmet or other protective head gear is normally not required.

The band 82 is of flexible and resilient construction, in this embodiment of synthetic plastics construction, and is constituted by two parts, which for ease of reference are both indicated by reference numeral 84. The two parts 84 are secured together at the back of the head 14 of the sportsperson, with an end portion 86 of each part 84 defining an ear shaft for receipt over the ears 26, 28 of the sportsperson. The two parts 84 are slidably interconnected, relative to each other, by a connection 86. The slidable connection of the two parts 84, in combination with their resiliently flexible construction, facilitates comfortable use or wear of the assembly 80 on a range of differently sized and shaped heads of sportspersons.

The assembly 80 also includes two attachments 88 (see also Figures 11 and 12) which, in use, perform the same function as the attachments 22. The attachments 88 are respectively releasably attached to the free end portions 86 of the parts 84, so that they are respectively located forwardly from the respective ears 26, 28 of the sportsperson. In this embodiment, the attachment formations by means of which the attachments 88 are secured to the parts 84, are indicated by reference numeral 90.

The attachment formations 90 each include a clip 92 which is releasably attached to its associated attachment 88, as hereinafter described. Each clip 92 is releasably clipped to the free end portion 86 of its associated part 84. The clips 92 are of generally C-shape when seen in end view, each clip 92 defining a receiving space within which its associated part 84 is received. The free end portions 86 of the parts 84 have circular cross-sectional profiles, so that the attachments 88 are pivotable relative to said free end portions 86.

Each attachment formation 90 further includes an elongated flexible

stiffening member 94 fast with its associated clip 92 releasably securing the clip 92 to its associated attachment 88. Because the stiffening members 94 are releasably secured to the attachments 88, the attachments 88 and the attachment formations 90 are independently replaceable when worn or damaged. The stiffening members 94 extend along outer faces 95 of front parts of the attachments 88, and are secured to the respective attachments 88 by means of three longitudinally spaced, laterally projecting headed pins 98 extending through mating apertures 97 through said front parts of the attachments 88. To this end, recesses 100 are provided in the attachments 88 for receiving the heads of the pins 98.

The clips 92 are secured to the respective associated uppermost pins 98 by means of elbow-shaped stems 96 respectively fast with said upper pins 98. When seen in front elevation, the attachments 88 include recesses 102 adjacent their upper edges 66, in which recesses 102 the clips 92 are located, and in which recesses 102 the free end portions 86 of the parts 84 are received.

As can be seen in particular in Figure 11, the width of the stiffening members 94 decreases towards their lower ends, thus resulting in reduced stiffness of the stiffening members 94 towards their lower ends. As will be appreciated, the attachments 88 are only secured to the band 82 adjacent their upper edges 66, and the reduced stiffness of the stiffening members 94 towards their lower ends thus provides for more or less even contact force or pressure between the inner edges 40 of the attachments 88 and the sides 42, 44 of the face of the sportsperson.

The assembly 80 is further provided with stops 104 (Figure 10), which are generally of U-shape when seen in plan view, fast with the free end portions 86 of the parts 84 and extending over and across the stems 96 for restricting pivoting of the attachments 88 in a direction indicated by arrows 106. Thus, when the assembly 80 is secured to the head 14 of a sportsperson, the attachments 88 can not pivot outwardly away from the sides 42, 44 of the sportsperson's face. Pivoting of the attachments 88

in a direction indicated by arrows 108 is however not restricted, thus providing for pivoting of the attachments 88 in the direction of arrows 108 when the assembly 80 is not secured to the head 14 of a sportsperson, typically when the assembly 80 is to be stowed or when the band 82 is received around the neck (not shown) of a sportsperson.

The invention as described and illustrated, will thus, in practice, reduce wind noise levels or volumes experienced by a sportsperson during movement in a forward direction, thereby enabling the sportsperson more easily to identify other forms of noise such as traffic in the case of a cyclist. Although the Applicant does not wish to be bound by theory, it is believed that the particular construction of the attachments 22, 88 will, in use, also serve to deflect noise coming from the sportsperson's rear towards the sportsperson's ears, thus enhancing the hearing, by the sportsperson, of noise from the rear.

DATED THIS 6th day of MAY 2004



**AV vR SCHWEIZER
ADAMS & ADAMS
APPLICANT'S PATENT ATTORNEYS**

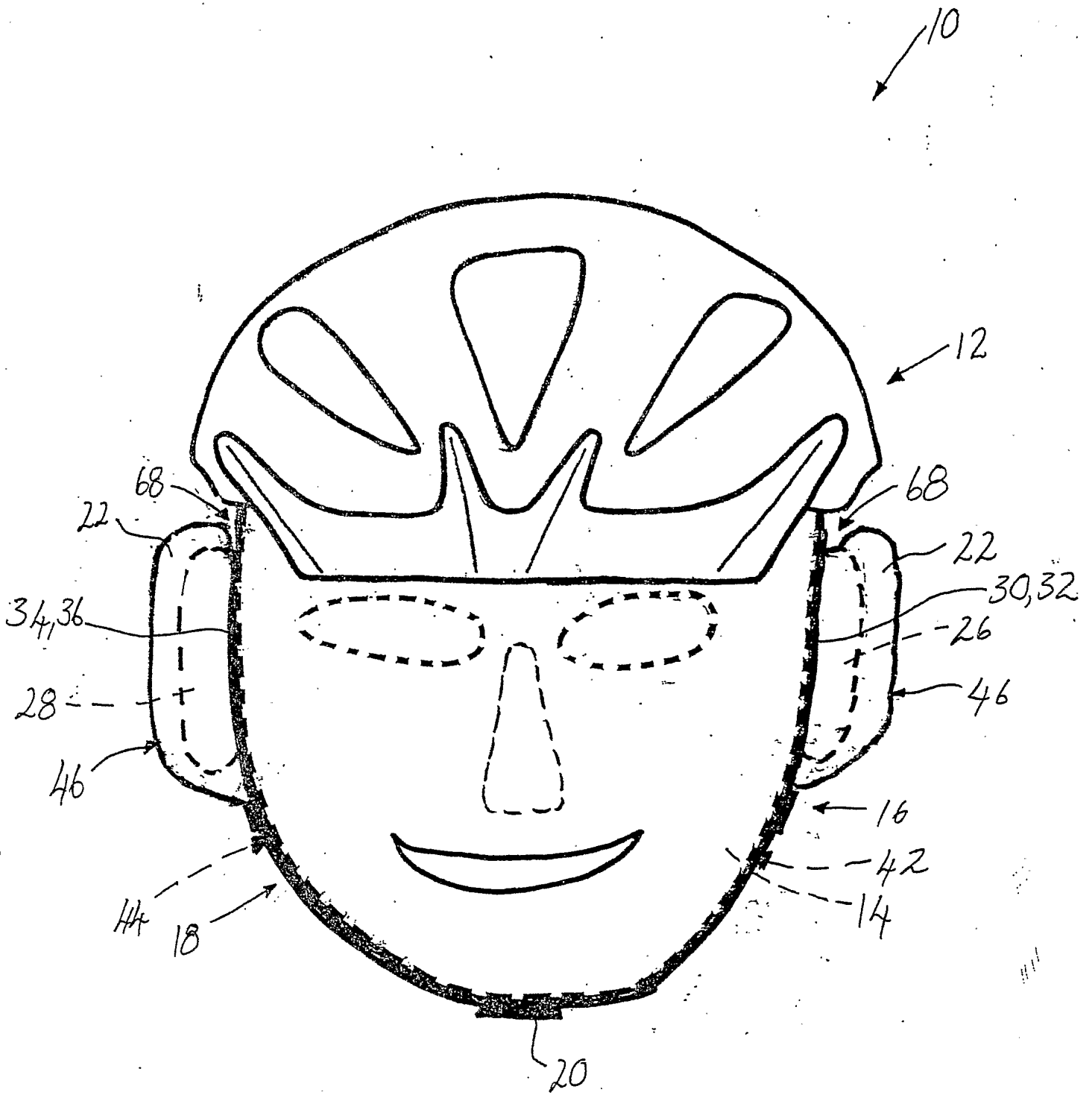



FIG. 1

AV VR SCHWEIZER
ADAMS & ADAMS
APPLICANTS' PATENT ATTORNEYS

TIEGS, Lonnie Dale

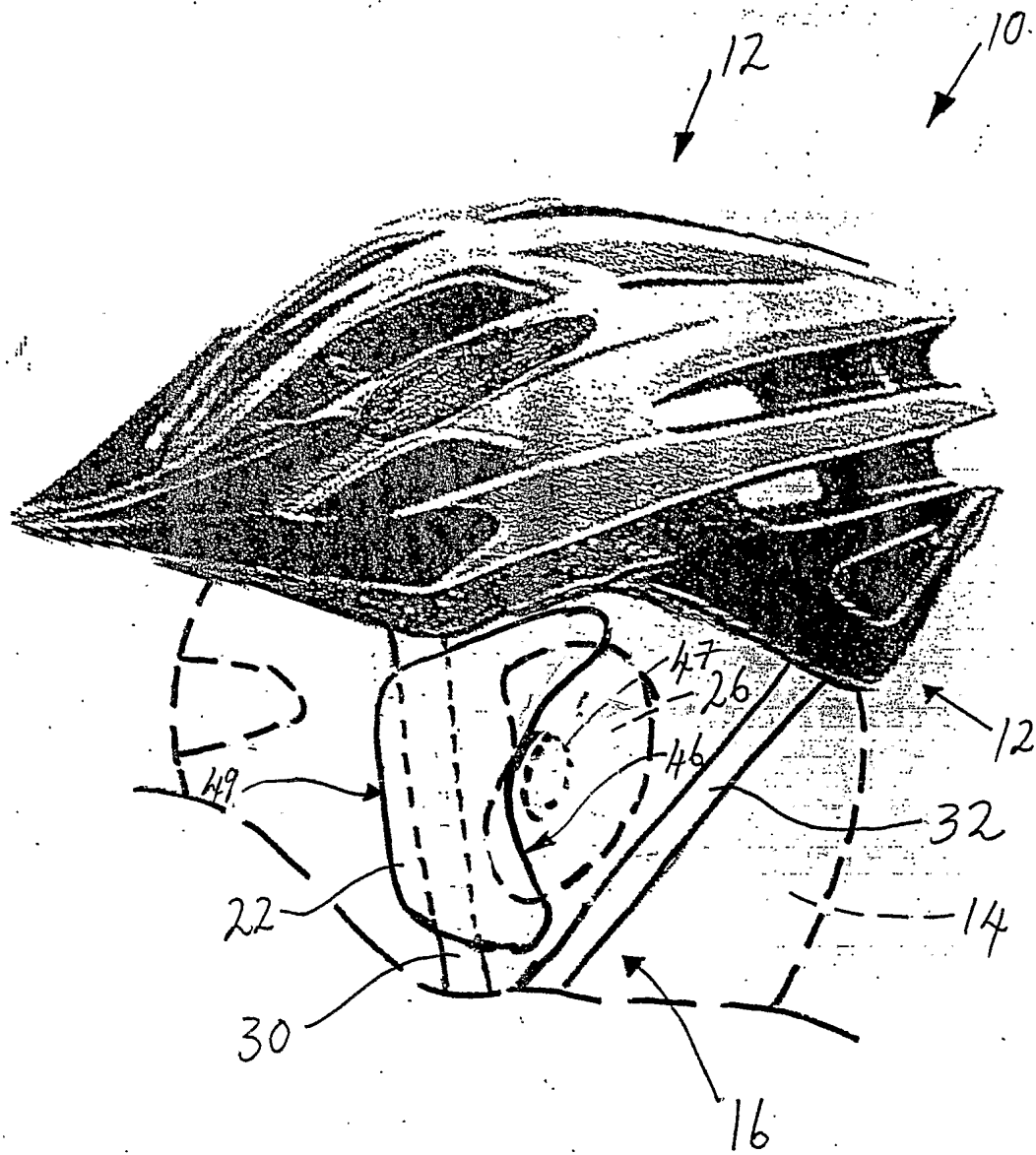

FIG. 2

AV vR SCHWEIZER
ADAMS & ADAMS
APPLICANTS' PATENT ATTORNEYS

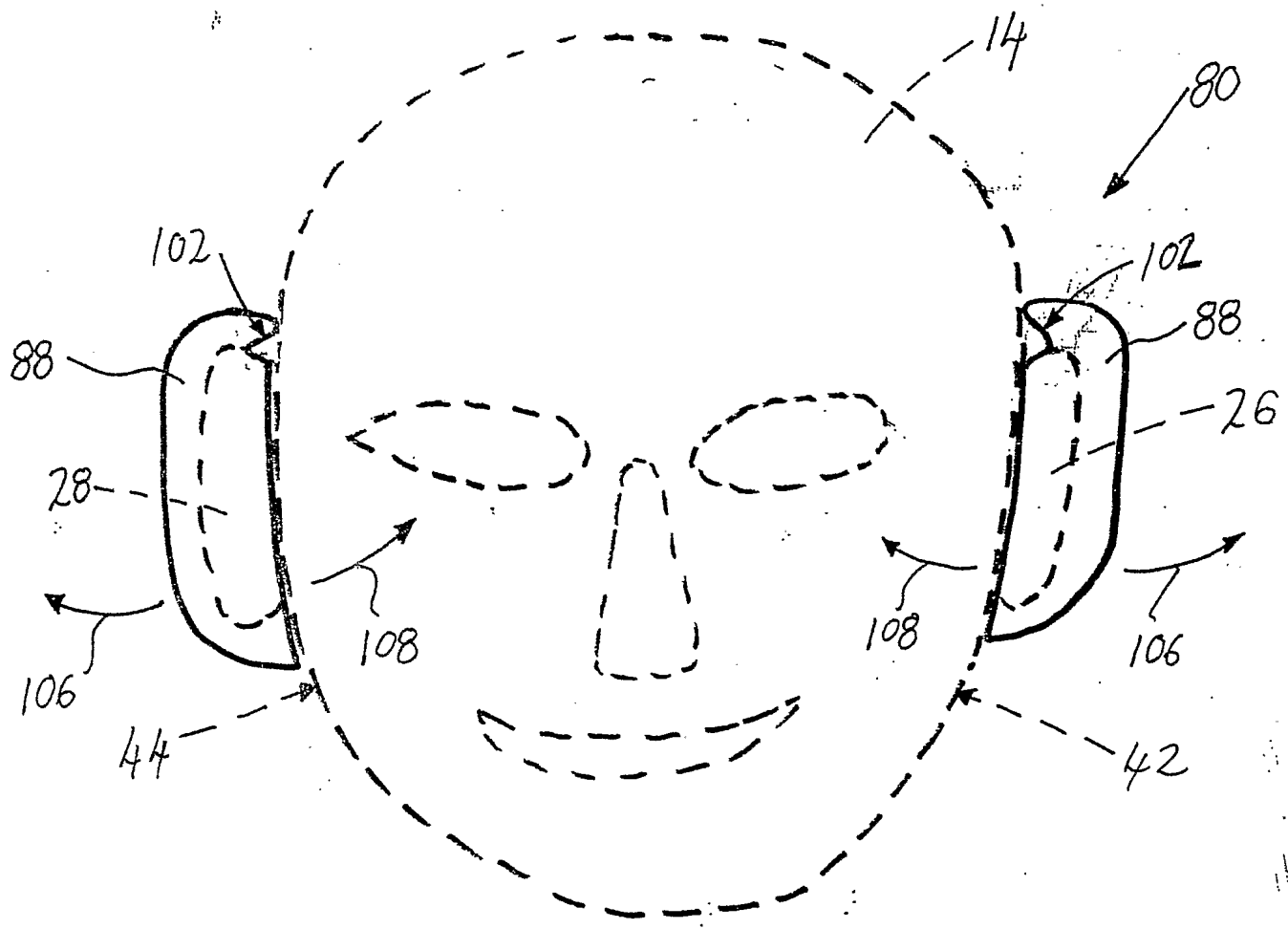



FIG. 3

AV VR SCHWEIZER
ADAMS & ADAMS
APPLICANTS' PATENT ATTORNEYS

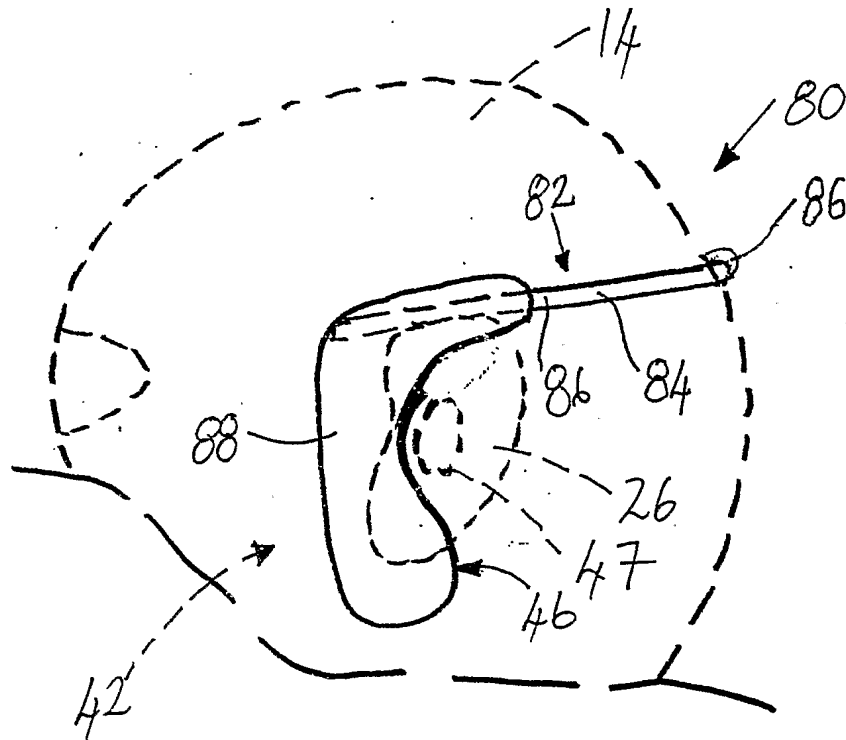

FIG. 4



AV vR SCHWEIZER
ADAMS & ADAMS
APPLICANTS' PATENT ATTORNEYS

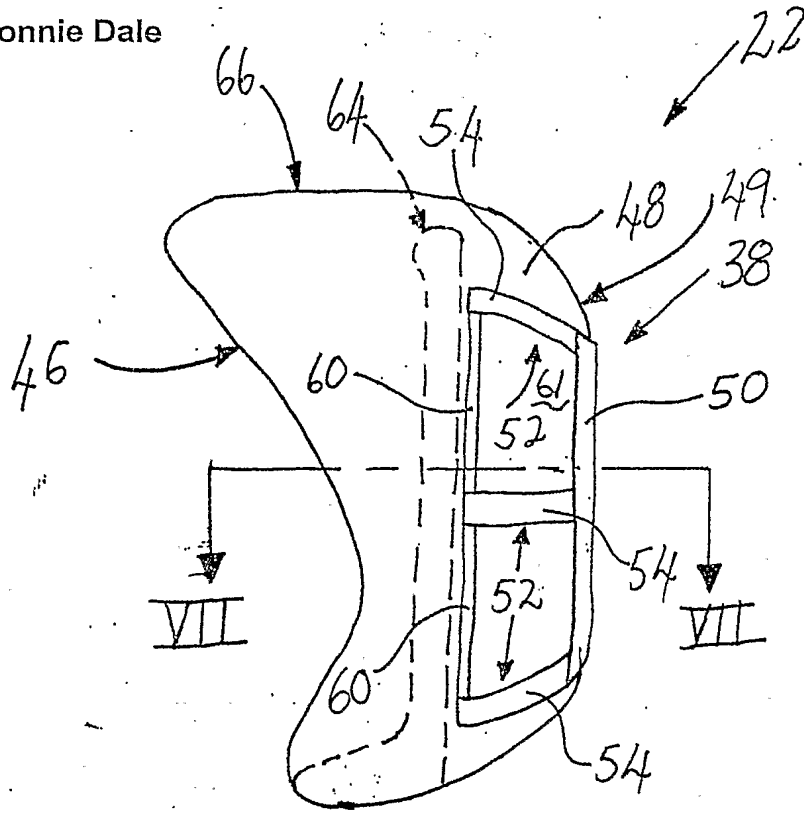

FIG. 5

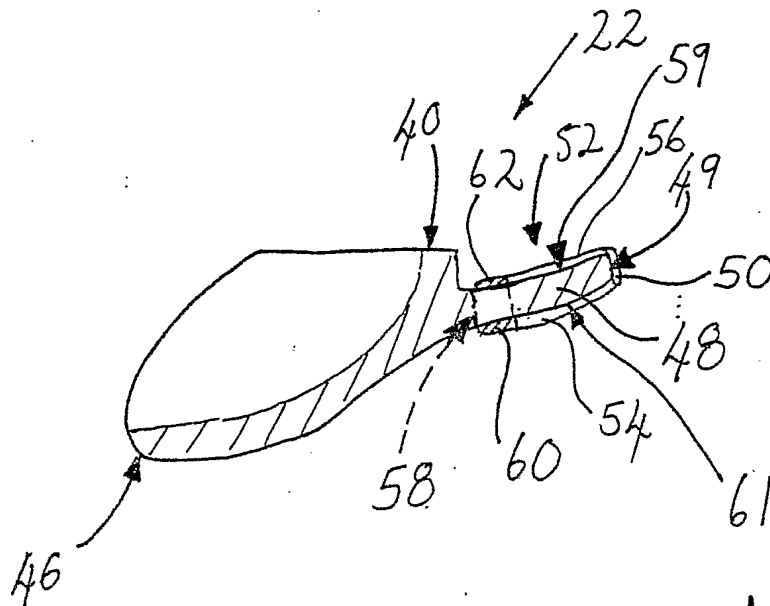



FIG. 7

AV vR SCHWEIZER
ADAMS & ADAMS
APPLICANTS' PATENT ATTORNEYS

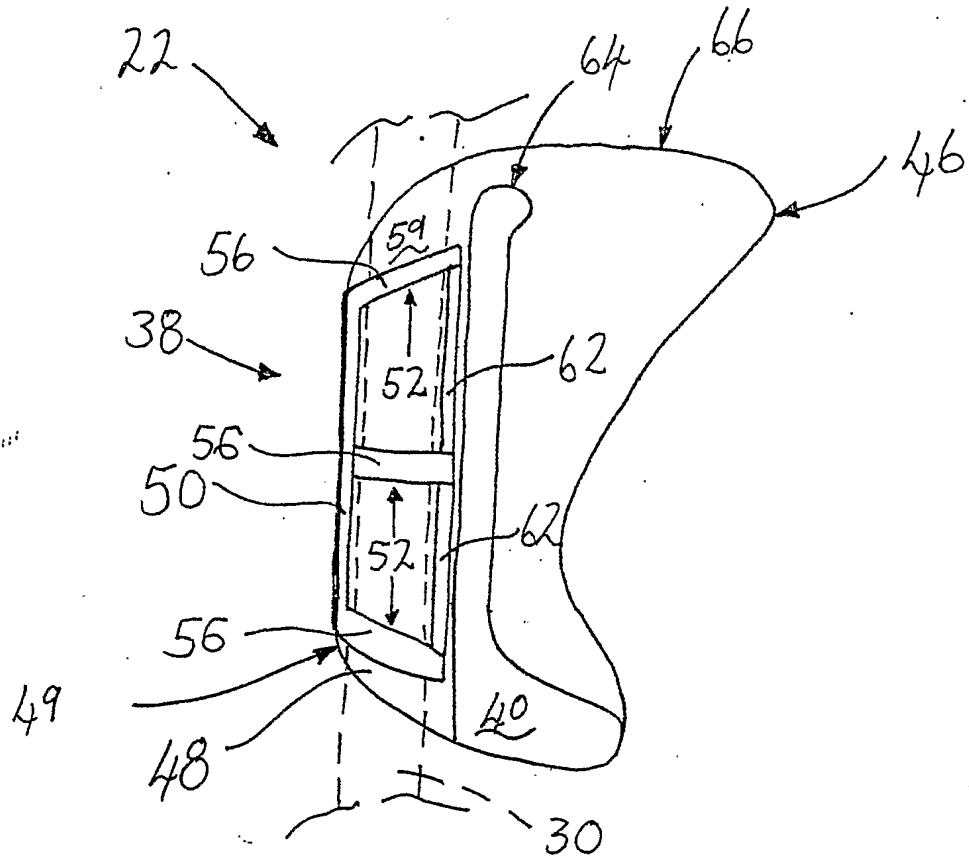

FIG. 6

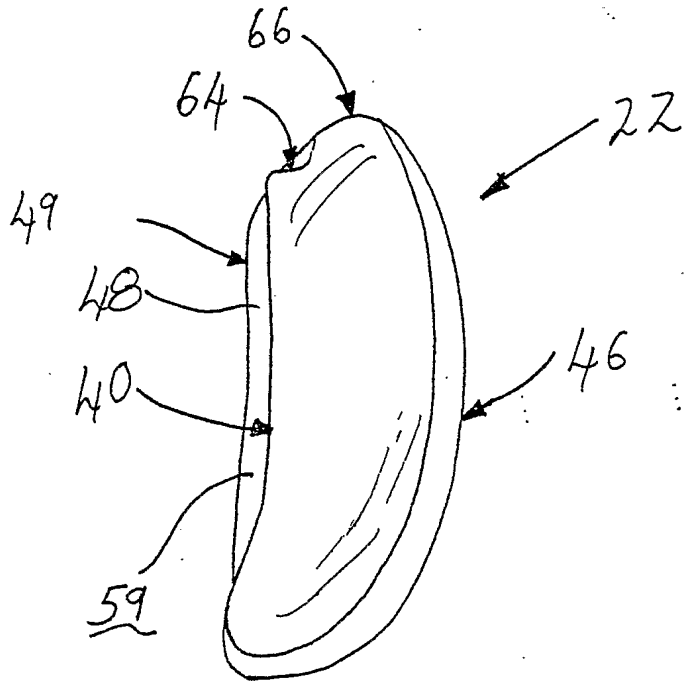



FIG. 9

AV vR SCHWEIZER
ADAMS & ADAMS
APPLICANTS' PATENT ATTORNEYS

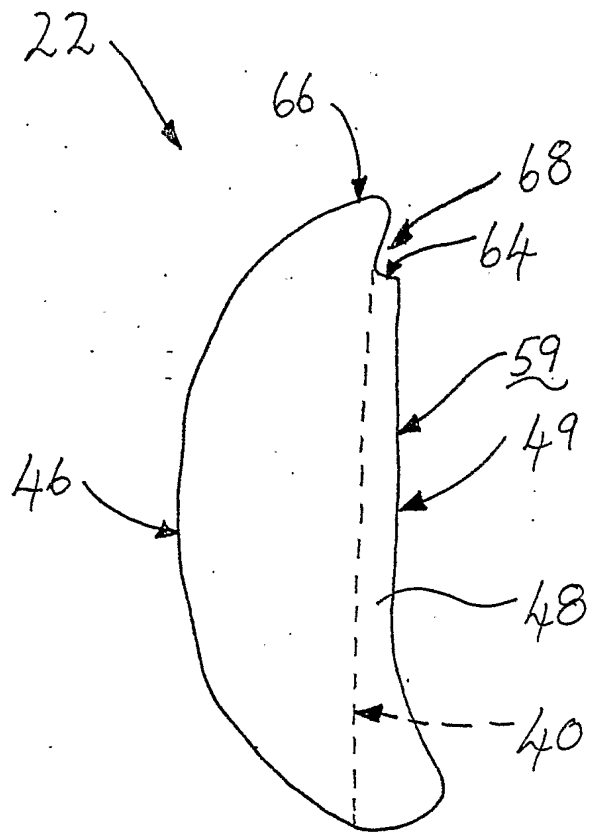



FIG. 8

AV vR SCHWEIZER
ADAMS & ADAMS
APPLICANTS' PATENT ATTORNEYS

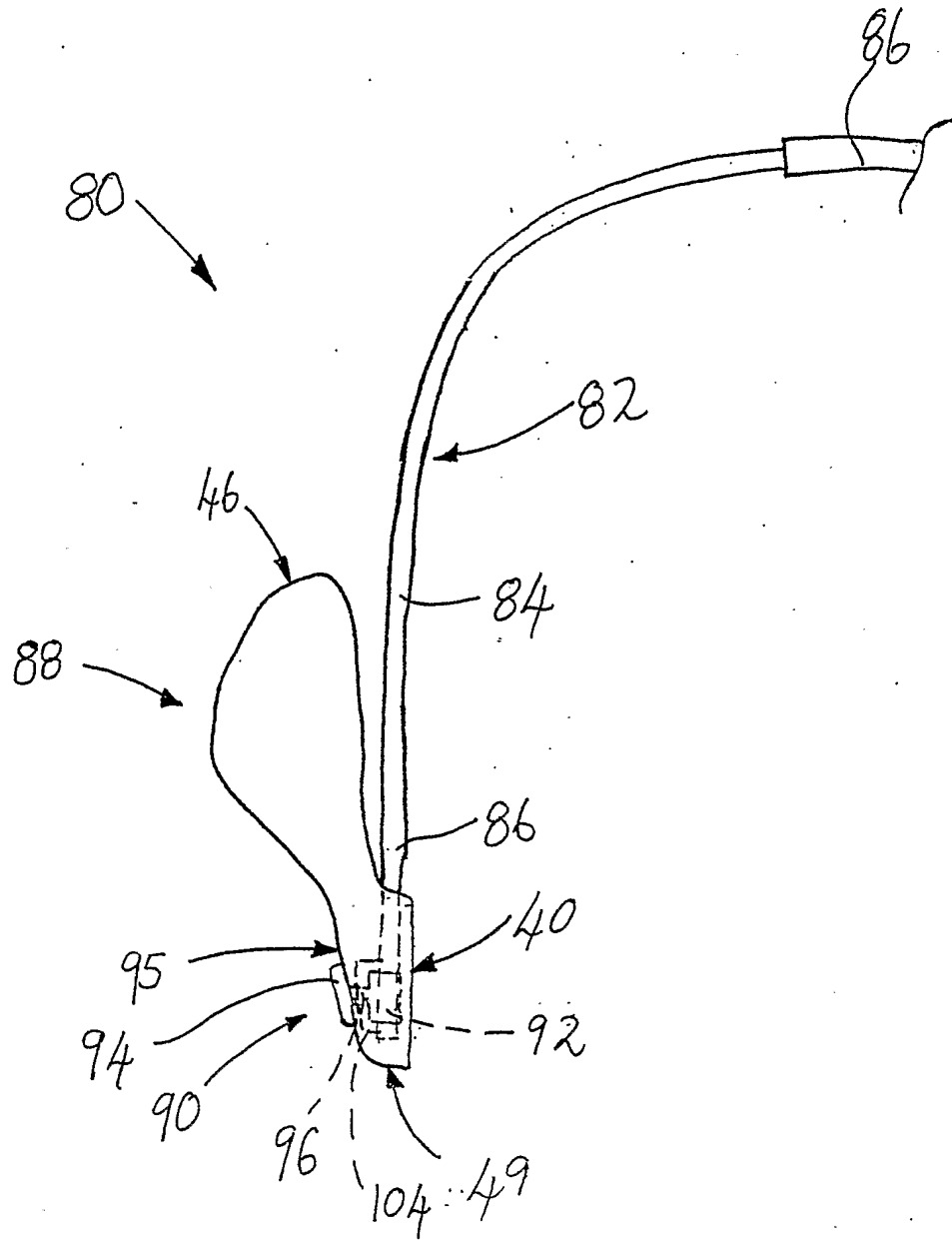



FIG. 10

AV vR SCHWEIZER
ADAMS & ADAMS
APPLICANTS' PATENT ATTORNEYS

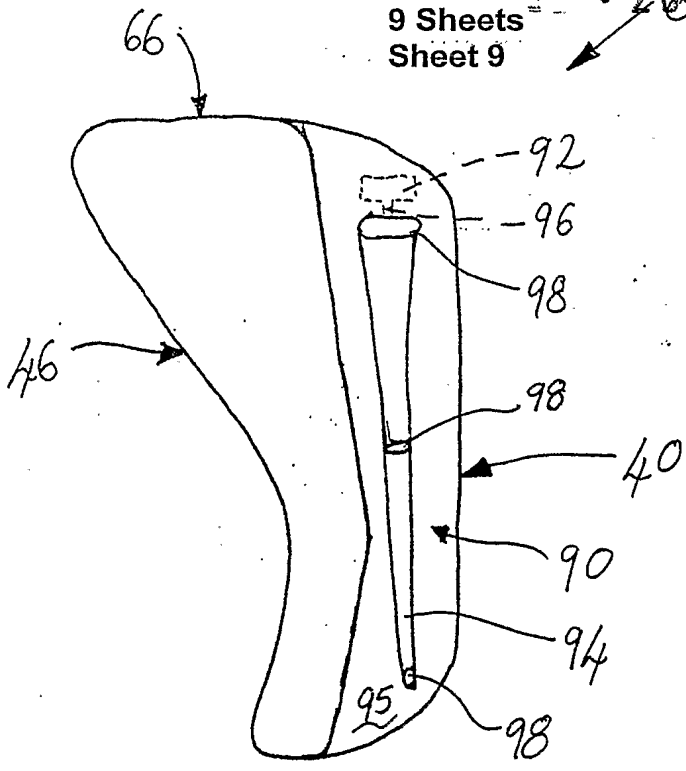

FIG. 11

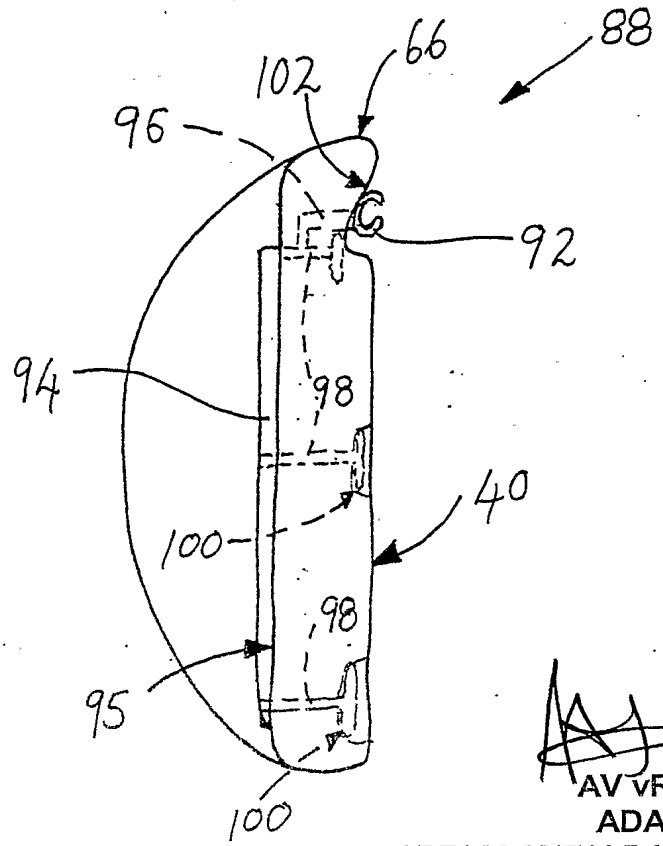

FIG. 12

AVR
AVR SCHWEIZER
ADAMS & ADAMS
APPLICANTS' PATENT ATTORNEYS